

全方位可持续包装解决方案提供商



**SuperMIX**

公司介绍



关于我们

公司经营理念

产品

设计

机器及设备

测试能力

色彩管理

环保与可持续发展

认证与证书

佳合科技作为中国包装行业的佼佼者,一直在为全球知名品牌和世界**500**强提供包装一体化解决方案的服务:

- 绿色、可持续性的包装理念;
- 个性化、人性化创意设计;
- 拥有国际颜色管理标准**G7**认证, **X-rite**印刷色彩闭环控制系统, 实现颜色数据化管理;
- **ERP**系统实现生产运营智能化控制, 生产成本细化, 客户订单时时追踪;
- 公司正式挂牌新三板, 股票代码: **872392**
- **2017**公司荣获高新技术企业

## SuperMix Group



昆山佳合

- 位于昆山开发区



常熟佳合

- 位于常熟通港工业园



越南立盛

- 位于越南平阳省



广德佳合

- 位于广德经济技术开发区

## 核心文化：

**诚实、创新、卓越、感恩**

**我们的愿景：**成为全球包装陈列一体化解决方案专家

**我们的使命：**产品一流、客户首选、员工热爱、股东满意

**我们的宗旨：**智能，创意和可持续的解决方案，提升品牌，增进绩效

**我们的守则：**专业、诚信、敬业、谦卑

**我们的团队：**激情、奉献、分享、责任、高效

## CSI ERP+ Printing Pack

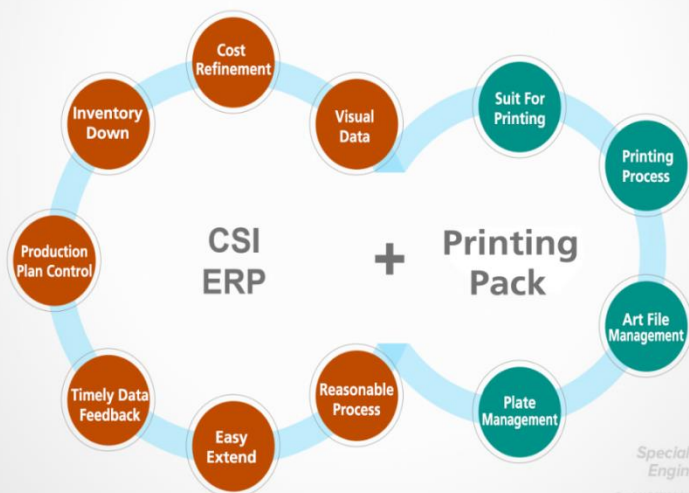

## Sytleline 流程框图

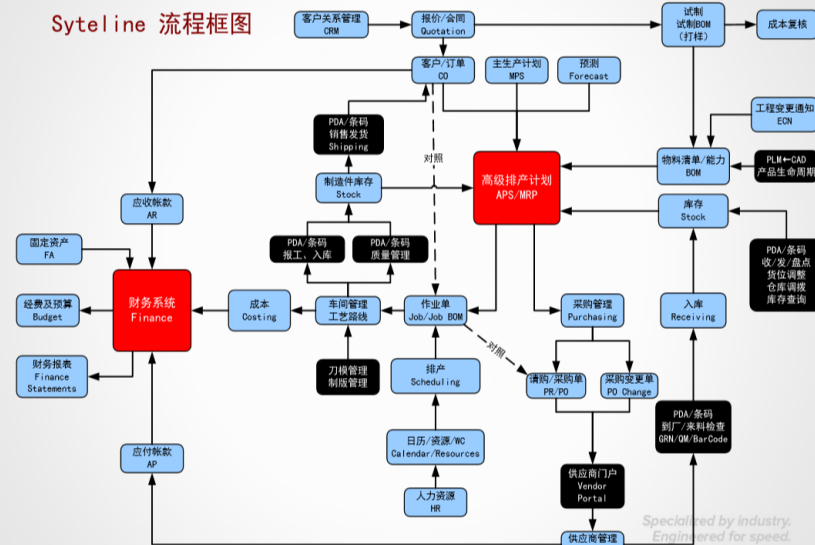

## 优势:

- 生产运营智能化控制
- 成本细分，降低损耗
- 实时订单追踪
- 智能化客户服务

# 我们的产品



- PDQ/POP展示盒
- 彩印纸盒
- 礼品盒
- 购物袋
- 彩印纸卡
- 柔印纸盒、纸箱





# 展示盒





# 彩印包装



# 彩卡、精品盒、纸袋



# 水印纸箱



佳合科技充分考虑客人包装诉求，一切从最优的方法满足客户需要：

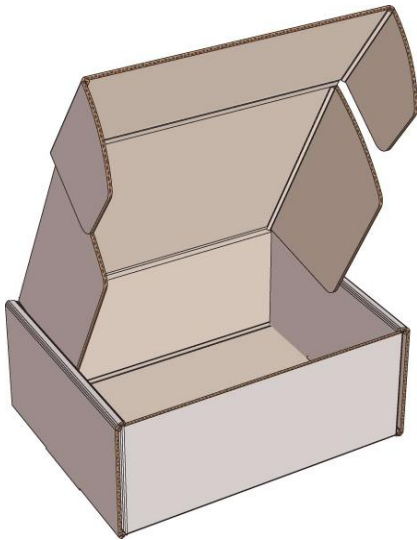

- 更好展示产品
- 优化成本
- 减少浪费
- 使用更多环保材料
- 设计可生产性工艺
- 降低破损率

## 结构设计



ArtiosCAD 16



Aoke DCZ 501115

## 平面设计

Adobe CC include:

- Photoshop® CC
- Illustrator® CC
- InDesign® CC
- Acrobat® XI Pro
- Bridge CC
- Device Central CC



GMG Color Management system



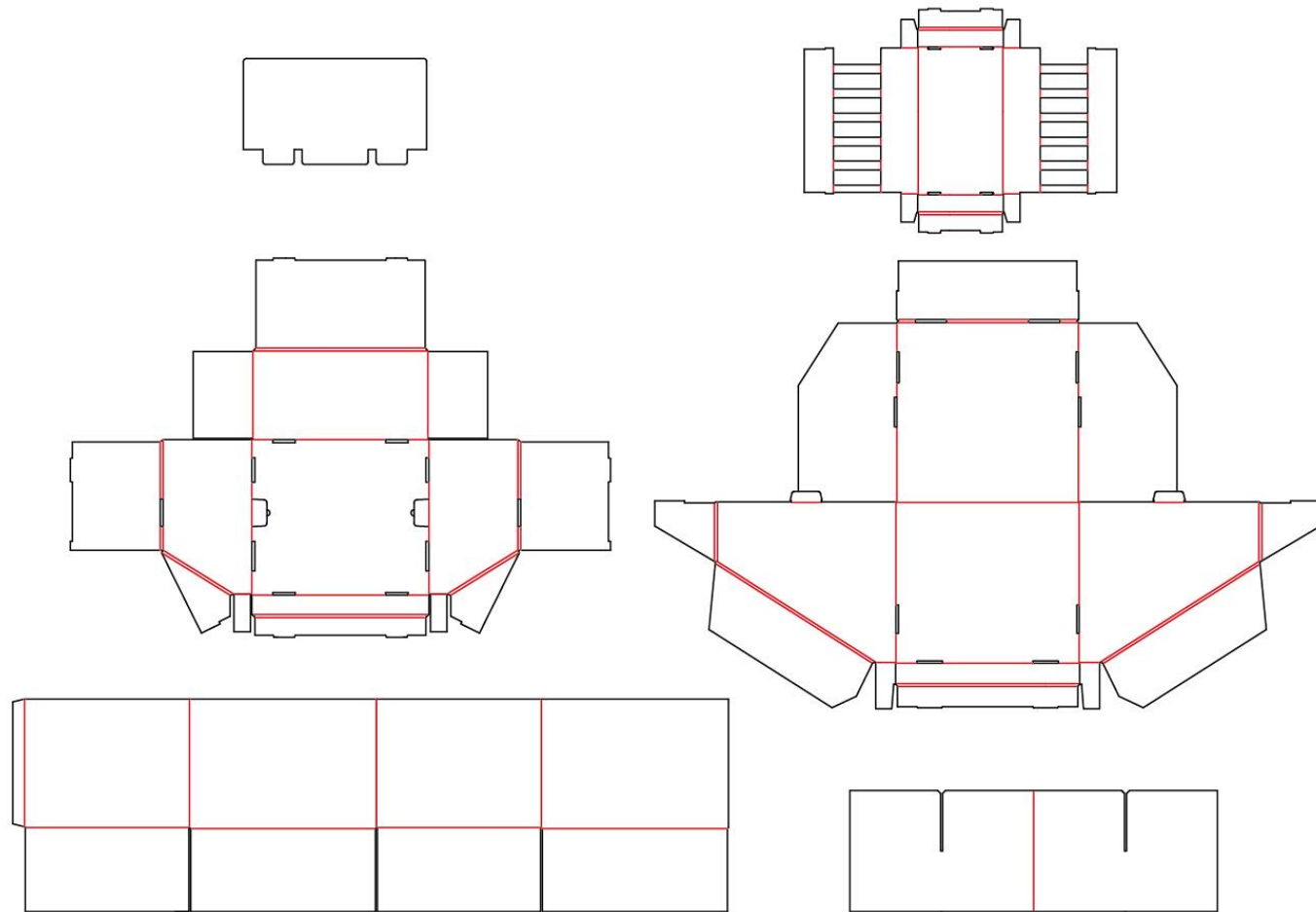

# 3D结构展示

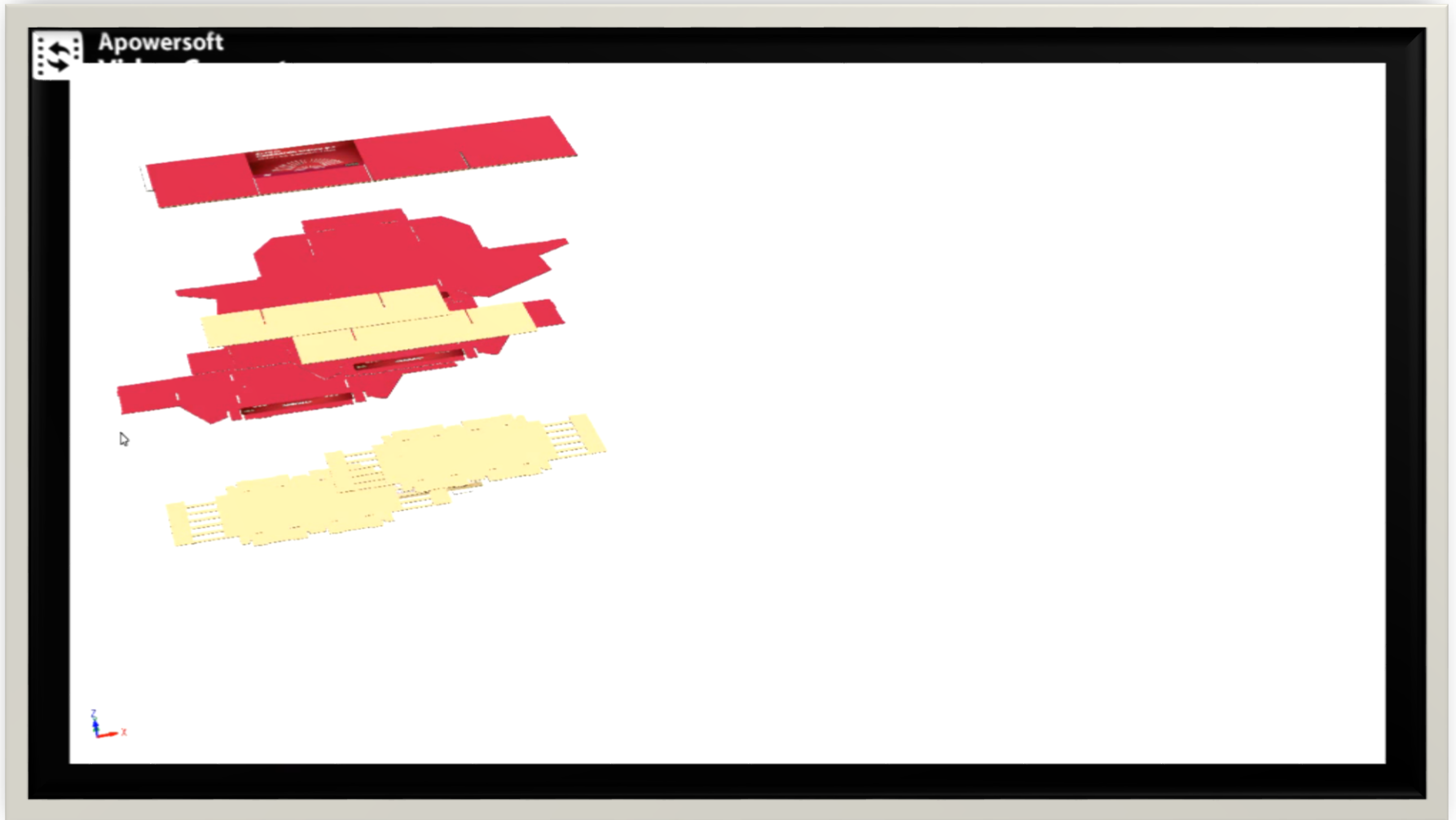



# 创意设计-多种解决方案

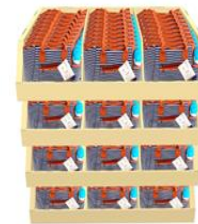
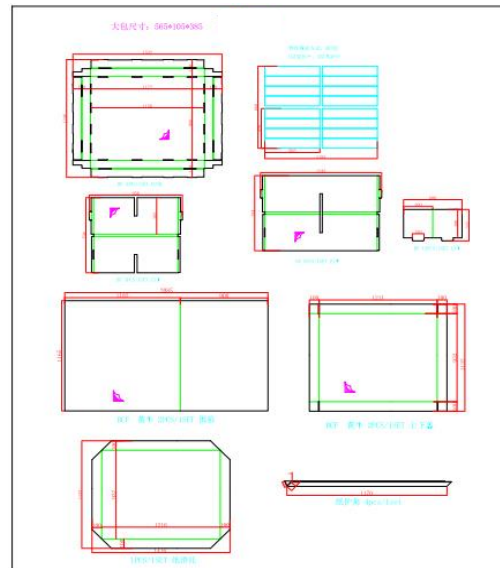

输入



设计



多样化解决方案

ImpactCAD模拟产品包装在超市的陈列展示效果，为客户带来更直接的视觉效果。



# 创意设计-白样制作

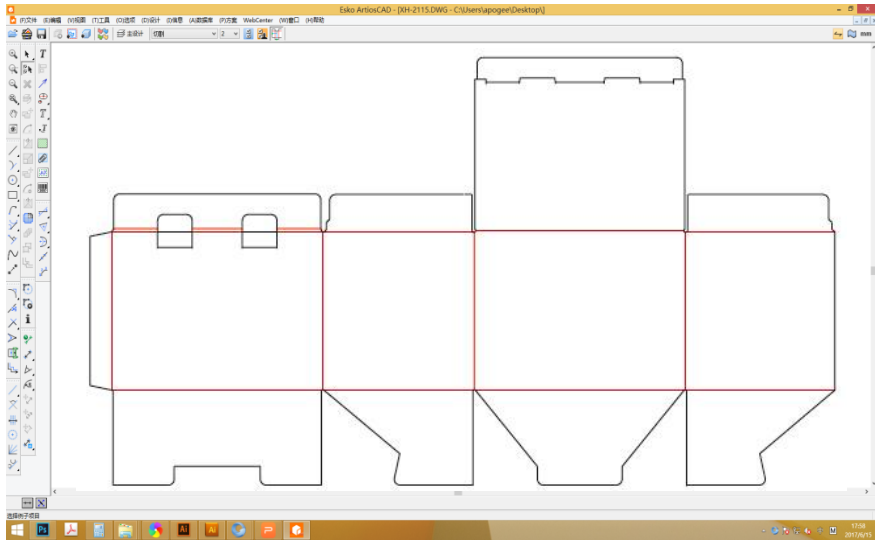

**CAD 结构图**

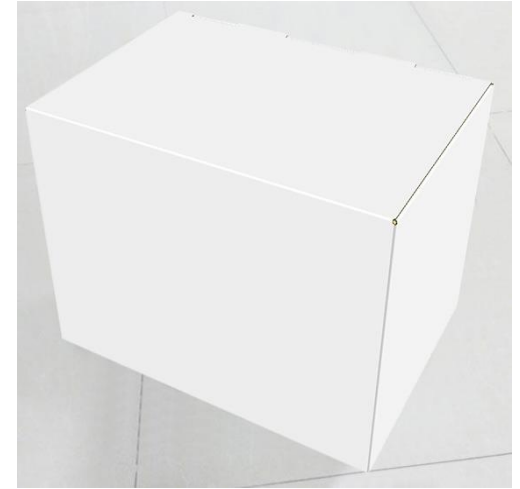

**成型**

**割样**



# 实样&小批量订单方案



高速UV打印



模切



成型

# 包装改进案例



改进前

改进后

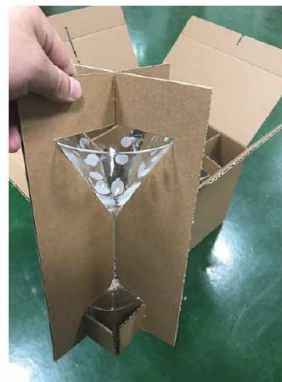

像杯子之类的玻璃制品，因为其易碎属性，在运输过程中需要很好保护，要有充分的缓冲，不能挤压。最初客户要求使用泡沫这种传统包装材料，但通过我们的创意设计，我们说服客户使用纸张结构来保护产品。此举节省了费用也为环保出了一份力。



# 包装改进案例

改进前

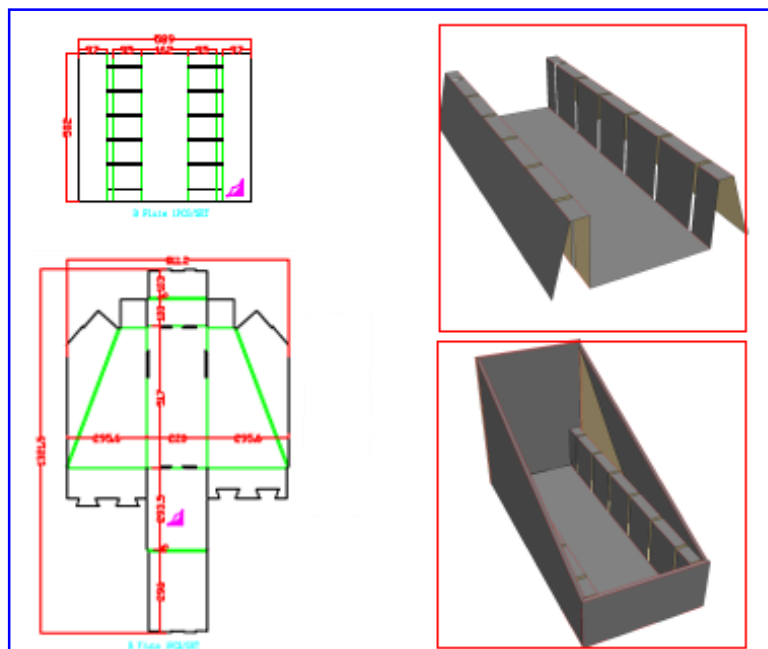

改进后

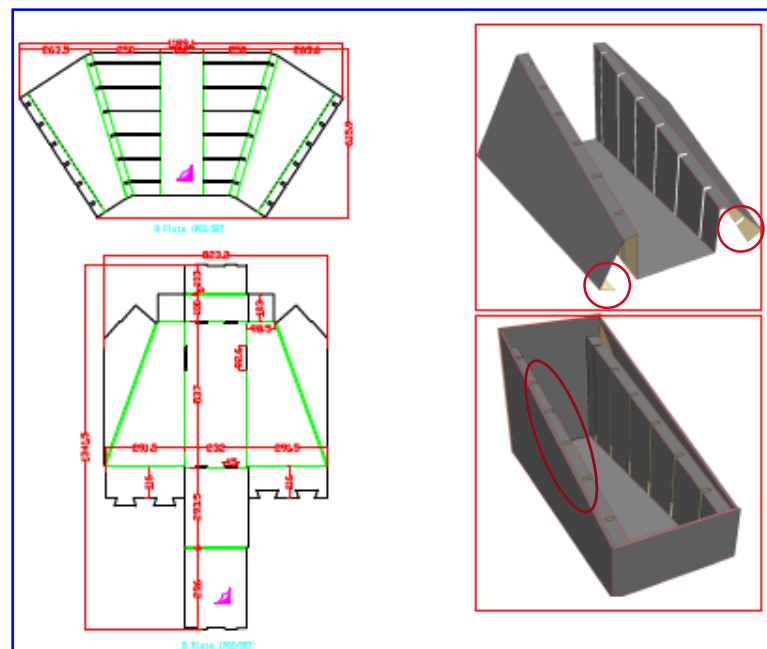

图上案例产品为灯具，很轻，之前客户用双瓦楞外箱但是没有通过测试.我们改善了内衬的设计，使其形成一个斜坡并在末端设计回折的形状，以便提供稳定及平行的力量支撑。因为内衬很好的发挥了作用，我们将外箱改为单瓦楞，重新测试并顺利通过。此举既满足了运输要求，也使包装费用下降15%。

## 7色高清水印

- 7色高清水印;
- 印刷、表面处理、模切一次成型;
- 环保水性油墨.
- 高画质细腻网点呈现，媲美胶印
- 缩短工期，灵活交货;





# 彩印设备



CTP



自动切纸机



KBA印刷机 1620



KBA印刷机 1050



上光机



裱纸机



模切机



糊盒机

# 水印设备



2.2m电脑控制五层  
纸板生产线



鼎龙印刷机 3C



1200x2800mm 4C印刷机



模切机



打钉机



HAIDA Small drop tester  
跌落测试



HAIDA Auto Box Press tester  
整箱抗压测试



HAIDA Vibration Tester  
振动测试



LAB Hydraulic Vibration Tester  
液压振动测试



LAB INCLINE IMPACT Tester  
斜撞测试



边压测试

HAIDA ECT Tester



耐破测试

HAIDA Auto Bursting Strength Tester



耐磨测试

Zhanseli Rubbing Tester



夹抱测试

Clamping Machine



恒温恒湿箱

HAIDA Temperature and Humidity Tester



## ISTA member ID: ST-10342

Testing Capacity	
1 series	1A,1B,1C,1D,1E,1G,1H
2 series	2A,2B,2C
3 series	3A,3B,3E,3K
6 series	6-AMAZON.COM-SIOC Type A,B,C,D,E,F,G,H
	6-FedEx-A,B, 6-SAMSCLUB
7 series	7D

## 色彩管理系统流程图:

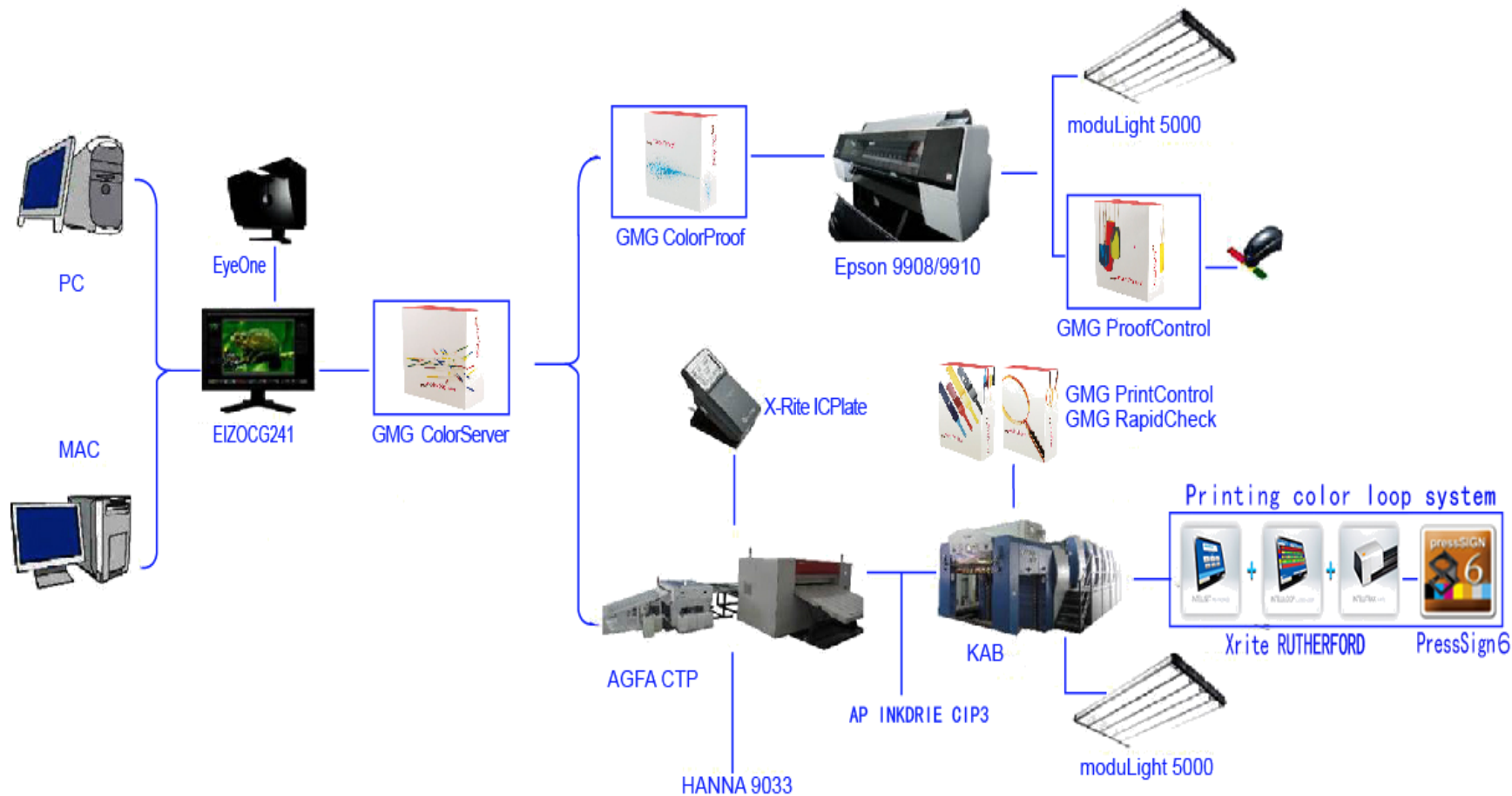

# X-rite印刷闭环色彩管理系统

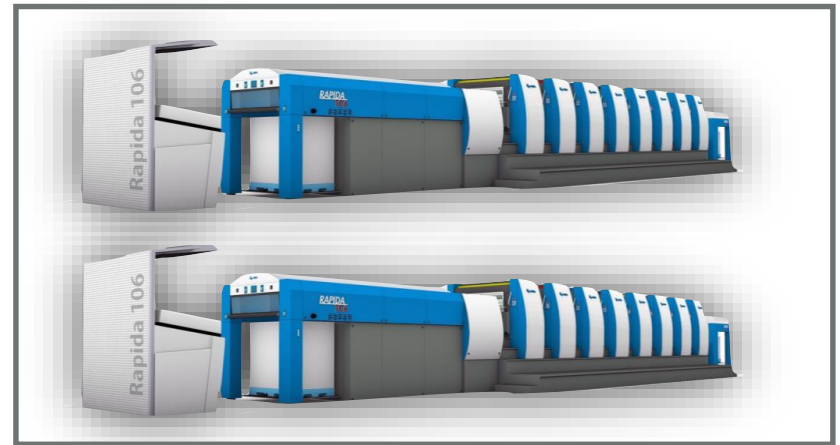

## 优点:

- 自动预设印刷墨量，自动预放墨。
- 内置ISO-12647-2国际标准。
- 快速测量印张，自动调节墨键控制墨量。
- 全过程精确检测，确保最佳印刷质量
- 缩短调机时间。



# 纸袋自动供墨系统



## 优点:

- ▶能安全、稳定、可靠、自动、定量地进行供墨；
- ▶减少油墨残留,降低印刷生产成本；
- ▶减轻操作人员工作强度；
- ▶消除固废处理,减少环境污染；
- ▶是现代印刷企业的标志之一.



# 环保与可持续发展



昆山佳合投资建立**630KW**太阳能发电设备，可供整个工厂**50%**用电量。

# 环保与可持续发展



昆山佳合投资建立污水处理系统，实现污水重复利用和零排放。

引入蒸发系统，最终将污水废水转化为固体废物，尽可能地降低废物处理费用。



昆山佳合已建立废气(VOC)处理系统，实现废气绿色排放。

# 我们的客户



Improving Home Improvement

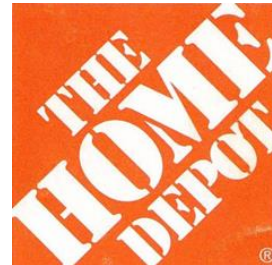

备注：所有客户认证包含了生产过程，质量和社会责任认证



# 认证及证书



**FSC**



**G7**



**GMI  
offset/flexo**



**ISTA**

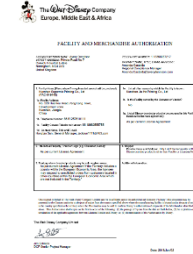

**FAMA**

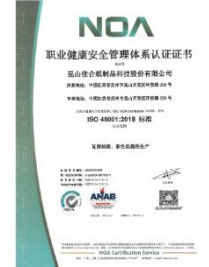

**OHSAS45001**



**排污批复**



**环保批复**

建设工程竣工验收消防备案情况登记表

工程名称	建设单位	监理单位	消防检测机构	消防检测机构名称	消防检测机构资质证书编号	消防检测机构资质证书有效期	消防检测机构项目负责人	消防检测机构项目负责人资质证书编号	消防检测机构项目负责人资质证书有效期	消防检测机构项目负责人联系电话	消防检测机构项目负责人身份证号	消防检测机构项目负责人身份证号有效期	消防检测机构项目负责人身份证号有效期	消防检测机构项目负责人身份证号有效期
昆山市佳合纸制品有限公司	昆山市佳合纸制品有限公司	昆山市佳合纸制品有限公司	昆山市佳合纸制品有限公司	昆山市佳合纸制品有限公司	昆山市佳合纸制品有限公司	昆山市佳合纸制品有限公司	昆山市佳合纸制品有限公司	昆山市佳合纸制品有限公司	昆山市佳合纸制品有限公司	昆山市佳合纸制品有限公司	昆山市佳合纸制品有限公司	昆山市佳合纸制品有限公司	昆山市佳合纸制品有限公司	昆山市佳合纸制品有限公司

**消防验收**



**安全生产认证**



**ISO9001**



**ISO14001**

Wal-Mart ES audit, Disney FAMA, Jcpenny ....



**期待与您合作！**